



Leeper's Stair Products
 2100 E. Artesia Blvd,
 Long Beach,
 CA 90805.



1(800) 775-1173



1(562) 422-9916



info@usa-fusion.com



www.usa-fusion.com

© Leeper's Stair Products 2007 / © Richard Burbidge Ltd 2007 02/07 AY099



a new concept in stair balustrading...

FUSION™

distinctive by design

distributed by

LEEPER'S STAIR PRODUCTS

LEEPER'S STAIR PRODUCTS

Contents

Introduction	3	Fitting Instructions	16-17
Fusion™ Specifications	4-13	Staircase Configurations	18-19
Step-by-Step Installation Guide	14-15	Components List	20-21



Timber: Oak, Connectors: Chrome Plated, Balusters: Chrome Plated.



FUSION™

> Sleekly designed connectors fix the rails and newels together and ingenious brackets fit the balusters to the minimalist round handrails and baserails.

innovation



- > Individually designed connectors create a distinct and unique look that will breathe life and texture to your home.
- > The Fusion™ of metal and timber creates a contemporary look that will set your staircase apart.
- > There are a variety of options available which can be mixed and matched to suit different tastes;
 - Rails and Newels - Oak, Cherry, Maple
 - Balusters - Chrome Plated & Brushed Nickel
 - Connectors - Chrome Plated & Brushed Nickel



s i m p l i c i t y



- > In most cases there is no requirement to make any modifications to components other than cutting the rails and newels to length. The cuts don't even have to be 100% accurate as the cut ends are hidden by the handrail connectors.
- > All balusters are also cut to suit either a staircase or landing installation.
- > The system can be installed using existing newel bases. Alternatively, if it is a new build or a complete refurbishment project, simply install newel bases and finish to match.

flexibility

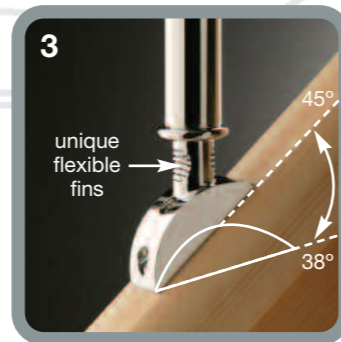
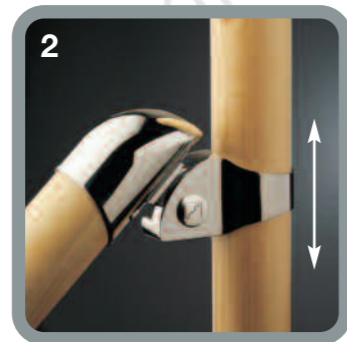

- > Fusion™ is suitable for domestic stair pitches between 38° to 45°, and handrail heights of 35 ⁷/₁₆" for stairs and 39 ³/₈" for landings.
- > The individual connectors allow significant adjustability to suit the majority of popular staircase configurations (Figs. 1 & 2).
- > The baluster brackets are designed to flex between 38° and 45°. Once fixed in place the ABS material they are made from means they will remain at the correct angle (Fig. 3).
- > Fusion™ stair balustrading system has been approved by the ICC-ES International Code Council Evaluation Service, Report ESR-1520 for compliance with the 2006 International Residential Code® (IRC) and 2006 International Building Code® (IBC). Fusion™ stair balustrading is Design Registered and Patent Pending. www.icc-es.org

1. Bottom Connector
The bottom connector can adjust to handrail pitches of between 38° and 45°.

2. Top Connector
The top connector has a sleeve that allows movement up or down to suit the pitch of the handrail.

3. Staircase Baluster
Due to its unique flexible fins, the staircase baluster is able to flex to pitches of between 38° and 45°.



versatility

11



> Fusion™ is versatile enough to use on a cut string staircase.

> A cut string staircase will give you an alternative style and opens up the look of your staircase for an authentic European feel.

1. Suspended Baserail Connector -
The baserail is suspended above the stairs and fixed to the newel base using these stylish connectors.

2. Mid Newel Base Connector -
A mid newel base and connector is essential, it adds strength to the overall balustrade.

3. Intermediate Newel Connector -
An intermediate newel connector allows the handrail to pass through adding strength to the balustrade.

time saving



- > Fusion™ offers a real alternative for those requiring a different look while considerably reducing the time required to install and finish.
- > A typical straight flight of timber balustrading requires over 100 saw cuts, Fusion™ requires just 7!
- > The chrome plated and brushed nickel balusters are ready to use, and unlike timber there is no need to cut, and sand down.





step by step installation guide

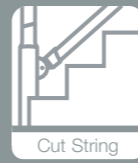

The string is the side of the staircase on which the balustrade is assembled. A cut string has the upper edge cut away to the shape of each individual step, so that the profile can be seen from the side. A closed string has the face housed to accommodate the steps, so that their profile cannot be seen. For full fitting instructions for both closed and cut string, please see the installation instruction leaflet packed with the newel base connector FMMNC.



1
After drilling your newel base, attach the threaded bar through the base into the barrel nut.



2
Secure the newel base connector onto the newel base using the fixings provided. Repeat steps 1 and 2 for all newel bases.



3
Measure and fit the baserail (this process differs for closed or open string staircases, see full fitting instructions in newel base connector for details).



8
Begin fitting appropriate landing balustrading.



4
After measuring your post to the correct length, fit and secure the posts in place. Repeat for all newel posts.



5
Attach the handrail using the bottom connector.



6
Fit the handrail to the correct angle using the top connector on the top post.



7
Begin fitting the balusters.



Job's done!



fitting instructions

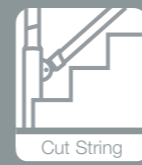
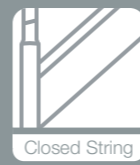

The string is the side of the staircase on which the balustrade is assembled. A cut string has the upper edge cut away to the shape of each individual step, so that the profile can be seen from the side. A closed string has the face housed to accommodate the steps, so that their profile cannot be seen. For full fitting instructions for both closed and cut string, please see the installation instruction leaflet packed with the newel base connector FMMNC.

Fusion™ stair balustrading comprises a patented system of round newel posts and handrails connected together using a series of metal brackets. Balusters fix into place using patented brackets designed to adjust to suit staircase pitches between **38° & 45°**.

Please check all components carefully PRIOR to installation for any damage to the surface. Please note Leeper's Stair Products cannot be held responsible for any damage once installation has commenced.

Fusion™ carries design registration and has patent pending. Genuine Fusion™ components carry the dovetail logo. Only genuine components have been independently tested to guarantee conformity to building regulations.

Fusion™ is designed for use in domestic situations and will fit closed string staircases with pitches between **38° - 45°** and handrail heights of **35 7/16"** stairs and **39 3/8"** landings. Fusion™ is tested to strength requirements of **0.36kN/m (24.6lbs force/ft)**

Fusion™ is manufactured to exacting tolerances, however as timber is a natural material some expansion and or shrinkage of the timber components can occur. If the newels and rails are slightly too big for the connectors, gently sand/shave the components to allow for a tight fit, being careful to only rework the area of the timber component that will be concealed by the metal connector. Alternatively if the timber component is loose in the connector, a rigid fix can be achieved using a proprietary gap filling adhesive.

Assembling Staircase Balustrading

Fusion™ will fit most staircase configurations. For further details please refer to the staircase configuration drawings in the brochure.

Fusion™ can be fitted to either existing or new newel bases. To use existing newel bases, these must be fixed centrally to the staircase string and the front face of the riser concerned (**Figs 1 & 2**).

Before removing existing newel bases, check that they are non-supporting or do not form a structural part of the staircase design.

When using Fusion™ your existing newel bases must be a minimum of **3 1/4" x 3 1/4"**. If less, face/build up existing bases using suitable facing material.

These instructions are for a straight flight with return landing.

Existing Bases

Fusion™ stairparts use cut balusters, and all cut-off points are referenced from the top of the baserail upwards. The system is designed to automatically compensate for any slight inaccuracies in cutting off the existing newel post. Before newel bases can be set to the correct height the baserail must be installed. To do this, lay the baserail on the stair nosings and resting against the inside faces of the newel bases, mark and cut accordingly taking time to ensure a clean and accurate cut. Place the baserail on top of the staircase string, but at this stage, a temporary fix is all that is required ie tacks on unfinished or masking tape on finished rails (**Fig. 3**).

Bottom Newel Base

From the line representing the top edge of the baserail mark a line

upwards through the center point of the newel base and where the two lines intersect measure up **6 7/8"** (**Fig. 1**).

Top Newel Base

The top newel base should be marked out in the same way as the bottom, but the height should be set at **4 19/16"** (**Fig. 2**).

It is important that existing newel bases are cut off squarely so that the newel posts are perfectly vertical. Once the bases are cut, trial fit the newel posts and check with a level. The top of the bases can be sanded level if required. This will reduce the height of the bases slightly but the newel assemblies can compensate for this within the connectors.

Newel Base Connectors

Newel base connectors (**FMMNC**) can now be fixed to the newel bases using the stud and barrel nut supplied. From the top of the newel base on the centre line previously marked, measure down **4 7/8"**. Using a **19/16"** spade bit, drill a hole to a depth of **19/16"** beyond the centre point of the newel base (**Fig. 4**). On the top of the newel base find the centre by drawing two diagonal lines from corner to corner. Using a **1/2"** spade bit drill to a depth of **4 7/8"**. Note all drill operations should be straight and accurate. Assemble the newel base connector (**FMMNC**) to newel base (**Fig. 5**) by locating the barrel nut and fully inserting the fixing stud. Place the newel base connector over the fixing stud and tighten nuts using **3/4"** socket/box spanner making sure that the connectors are positioned as illustrated (**Fig. 6**).

Note - in most cases when tightening the base connector to the existing bases, the retaining ring on the underside of the connector should pull into the newel base. However depending on the timber type it maybe necessary to disassemble the connector and chisel a clearance ring of approximately **1/8"** wide by **1/4"** deep allowing the newel base connector to sit flush. Cut the bottom newel post to a length of **20 11/16"** and drill a **1"** diameter clearance hole at a depth of **1"** to the underside of the post to allow it to fit over the stud assembly. Fix post to the connector using screws provided making sure the post is fully inserted. Fix the top post in the same manner but do not cut the post to length at this stage.

Note - to mark the position of the clearance hole in the newel post, place newel into base connector, knock gently and then remove post.

New Newel Bases

Fit new newel bases central to the front faces of the staircase risers checking that they are vertical and at the correct height (**Figs 1 & 2**).

Note - remember to add the thickness of the baserail when marking the intersection points as illustrated in (**Fig. 3**).

Fixing Connectors & Handrails

Fixing the handrails and connectors is best done by two people. To establish the correct angles of connectors and lengths of handrail, you will need to assemble two balusters. Fit the baluster brackets to the ends of the staircase balusters by inserting the screws supplied for a tight fit (**Fig. 7**). Note - ensure the baluster brackets are in line with each other by tightening the screws with the baluster held on two blocks of timber (**Fig. 8**). The balusters are cut to length and should not require any modifications.

The bottom connector (**FMMBC**) and top connector (**FMTC**) are a two-part assembly. Attach the newel post part of the connectors to the newel posts. Note - the top newel post connector slides over the top newel post and should not be permanently fixed at this stage. The handrail part of the bottom connector should now be attached to the overlong handrail. Offer the handrail assembly to the newel post connectors and to check that the handrail is parallel to the baserail and at the correct height, position assembled stair balusters to the underside of the handrail next to the bottom and top newel (**Fig. 9**).

Adjust the height of the top connector by sliding up and down the top post and check the balusters are vertical using a level. Mark the position of the top connector to the newel post using a pencil and with the overlong handrail to the side of the top connector mark and cut the handrail to the required length (**Fig. 10**).

Fit the top post connector in place by setting to the previously marked pencil line and secure the newel post part of the connector using the screws supplied. It is important that this connector is fixed so that it is in line with the bottom newel. Fix the handrail connectors to the ends of the handrail and then fix this assembly to all newel post connectors checking that everything is vertical and parallel before securing all connector bolts, nuts and screws. You are now ready to fix the first and last balusters. The last baluster must be fixed so that it is tight against the handrail connector so as to conform to building regulations. Position the baluster between the handrail and baserail, check for vertical and mark the position of the baluster bracket to the baserail with a pencil. Remove the baluster and fix the baserail to the staircase string using **1 3/4" No. 8 countersink screws**.

The screw fixing the baserail to the staircase string should be positioned so that it does not interfere with the baluster bracket fixing screws. Reposition the baluster and fix to the handrail and baserail using the screws supplied. Fix the bottom baluster and space so that the gap between baluster and newel post is no greater than **3 15/16"** (**Fig.11**).

To space the remaining balusters evenly up the stairs measure the distance between the spacing marks (notches on the side of the brackets) of the bottom and top balusters already installed (**Fig. 11**) and divide by **5 27/32"**. Round the answer up to the next whole number and divide this whole number back into your original measurement to give an exact spacing.

Example - **85"** between bottom and top spacing marks divided by **5 27/32" = 14.45**, rounded up to **15**.

85" ÷ 15 = 5 5/8" spacing measurement.

Fix all remaining baluster brackets to balusters using the screws supplied (**Fig. 7**) ensuring the brackets are in line using the blocks of wood described previously (**Fig.8**). Mark the spacing between balusters to the baserail either using a pencil and tape measure or by marking and cutting a piece of timber to the required length. Fix the assembled brackets and balusters to the baserail first making sure that on every 4th baluster you secret fix the baserail to the staircase string using **1 3/4" No. 8 countersink screws**. The top baluster brackets can now be fixed to the underside of the handrail using a level to check for vertical.

Note - if you have a particularly short flight of stairs you may need to re-space the balusters to provide a more pleasing effect, remembering at all times to space them no more than **3 15/16"** apart.

Assembling Horizontal/Landing Balustrades

Using standard Fusion™ components you will require a minimum **4 3/4"** measured from the centre of the staircase baserail to the centre of the landing baserail for stairs with landings at 180° to the stairs (**Fig. 12**).

Cut and mitre the landing baserail to size and place into position on the landing. Do not fix to the landing floor at this stage (**Fig. 12**). Fix the landing baluster brackets to the landing balusters. Place an off-cut of handrail loosely into the landing connector (**FMMLC**). Position one assembled landing baluster onto the baserail and place the handrail and connector on top of this baluster and to the side of the top newel to establish the required height of the post. Mark and cut to suit.

Where the landing balustrade ends against the wall, mark the position of the wall connector (**FMMWC**) on the wall by placing an assembled landing baluster and baluster connectors to off-cuts of baserail and handrail. Mark the position of the wall connector (**FMMWC**) to the wall and drill and plug to suit. Note - before drilling and plugging this fixed point check that the landing handrail will be parallel using a level, if the landing floor is slightly out, reposition the wall connector (**FMMWC**) and pack the underside of the landing baserail accordingly.

Place an off-cut of handrail to the landing connector (**FMMLC**) and position on the top newel. Push the landing handrail into the wall connector (**FMMWC**) and offer the horizontal turn (**FMMHTR** or **FMMHTL**) to where the two handrails meet to establish lengths of cut. Mark and cut the handrails to the required length. Reposition the landing handrail to the wall connector (**FMMWC**) and fix horizontal turn (**FMMHTR** or **FMMHTLS**) to the other end of this rail. Fix the short return length of handrail onto the other leg of the horizontal turn (**FMMHTR** or **FMMHTL**) and the landing connector (**FMMLC**) to the other end of this short return length of handrail and position over the top newel post (**Fig. 13**).

Note - before screwing all connectors to rails and top post, we recommend a final check for parallel. Use a level for the handrail and an assembled baluster/baluster brackets between the rails.

To calculate the exact number of landing balusters either divide the total landing length by **4 19/32"**, which will give a gap of approximately **3 3/4"**, or alternatively you may find it aesthetically more pleasing to space the landing balusters so that they are in line with the staircase balusters. Mark the position of the baluster brackets to the baserail and secret fix the baserail to the landing floorboards using **1 3/4" No. 8 countersink screws** every 4th baluster.

Assemble all baluster brackets to the ends of the landing balusters by inserting the relevant fixing screw (**2 1/2" No. 8**) into the underside of the brackets and tighten (**Fig. 7**). Ensure that the brackets are in line with each other as previously described for staircase balusters using two square blocks of timber (**Fig. 8**).

Fix all bottom baluster brackets to the baserail using **1 1/4" No. 6 screws** and finally secure the top baluster brackets to the underside of the landing handrail using **1 1/4" No. 6 screws** checking for vertical with a level.



fitting instructions

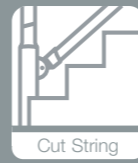

The string is the side of the staircase on which the balustrade is assembled. A cut string has the upper edge cut away to the shape of each individual step, so that the profile can be seen from the side. A closed string has the face housed to accommodate the steps, so that their profile cannot be seen. For full fitting instructions for both closed and cut string, please see the installation instruction leaflet packed with the newel base connector FMMNC.

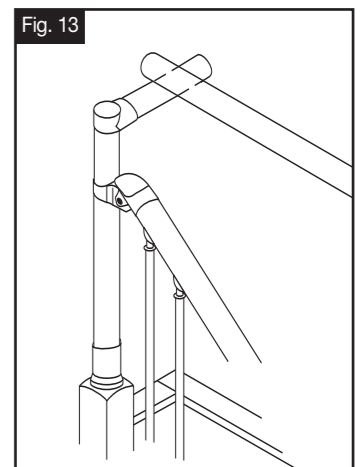
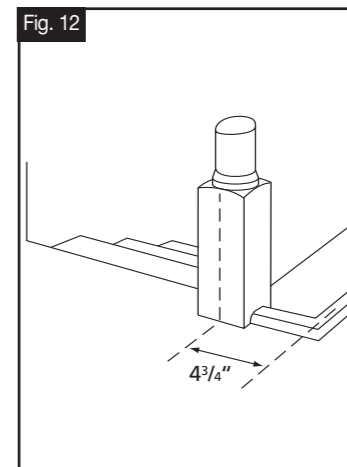
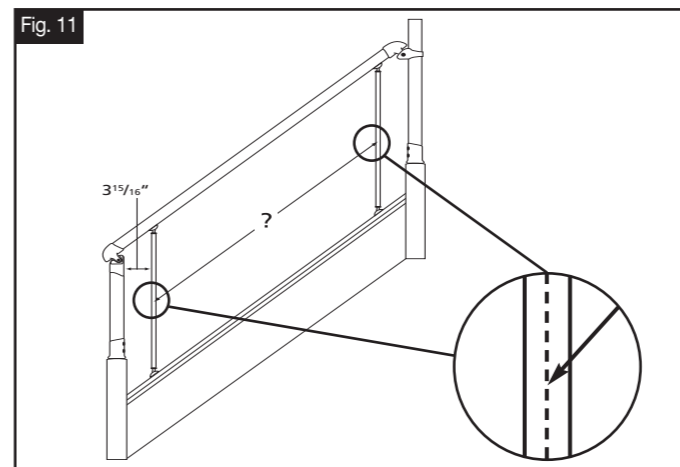
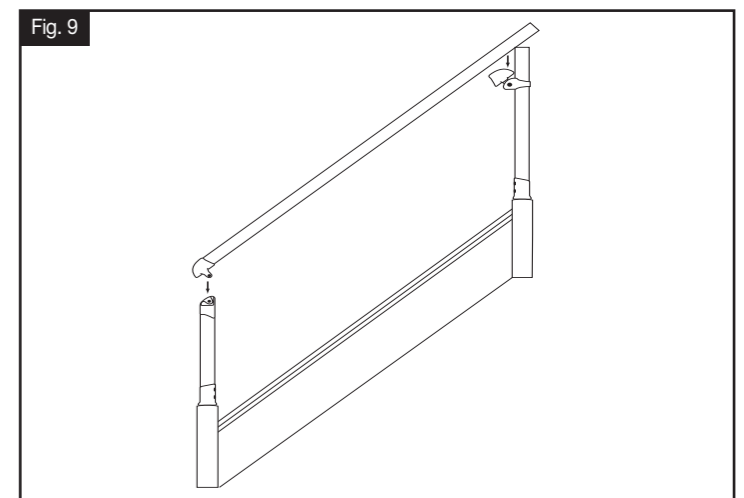
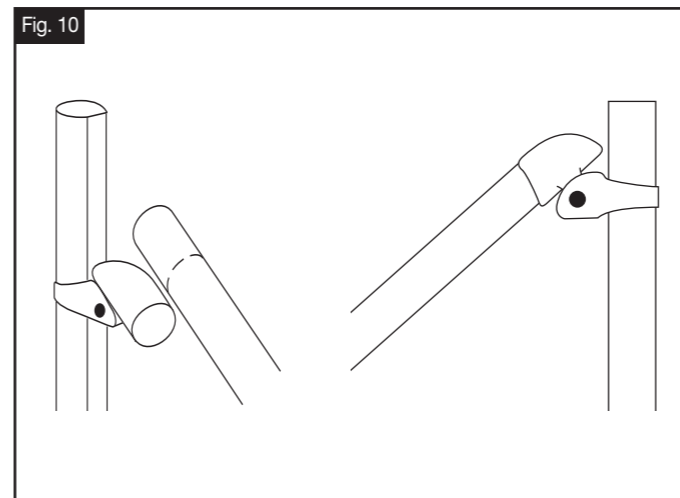
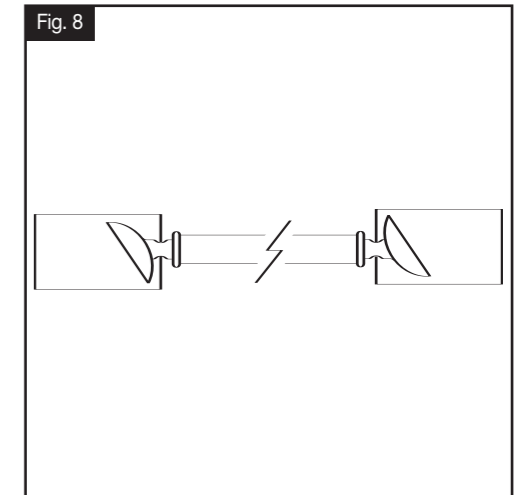
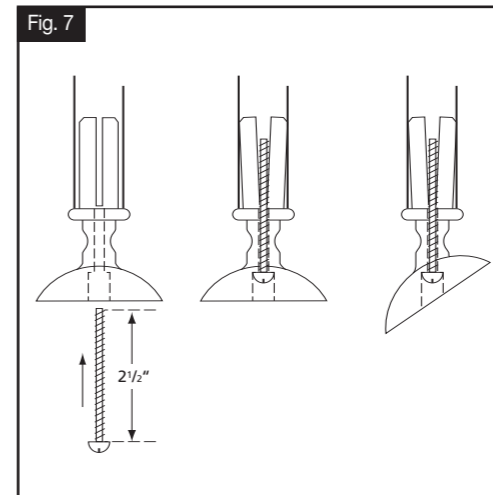
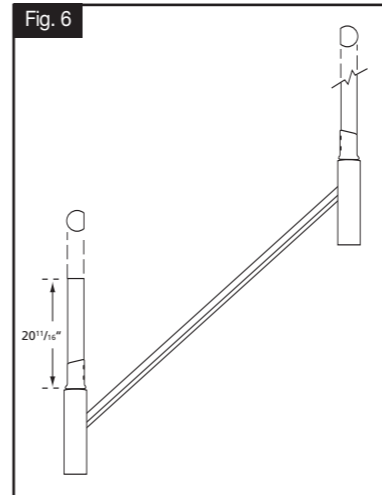
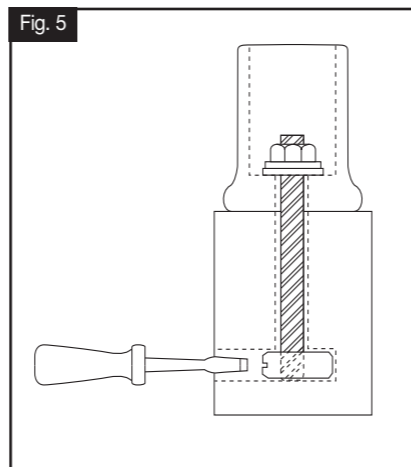
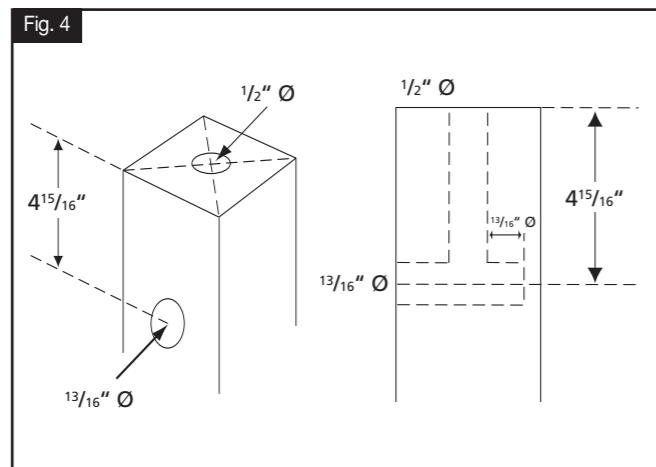
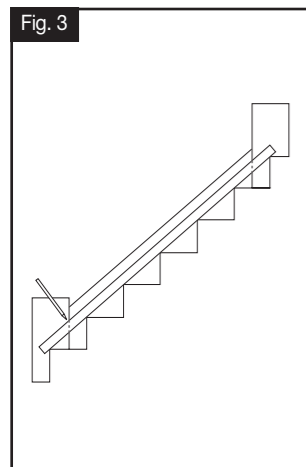
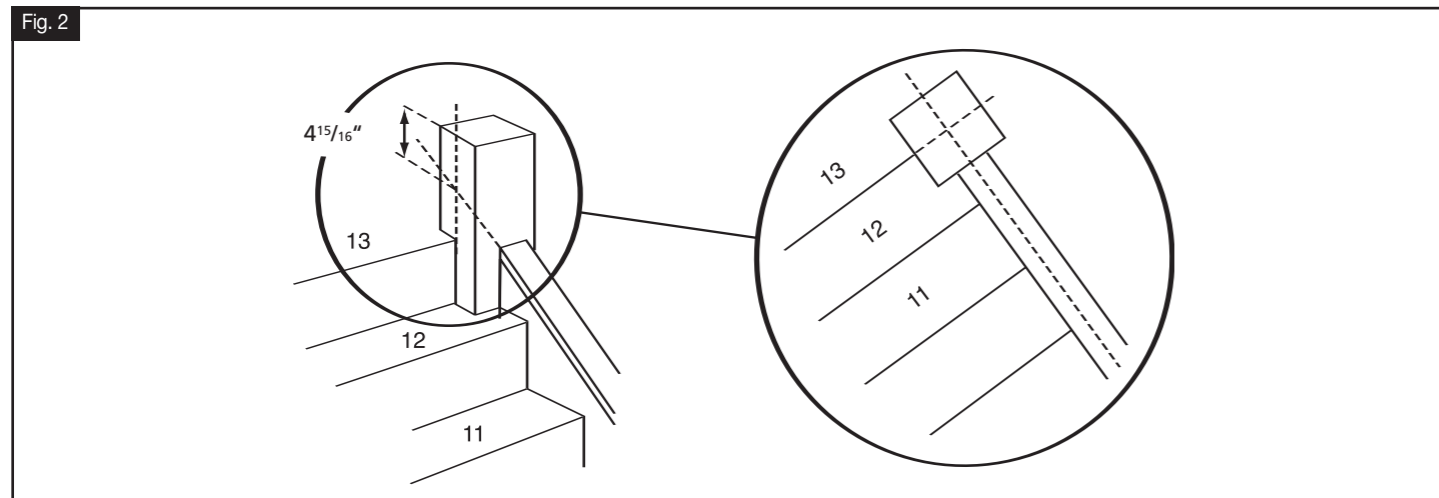
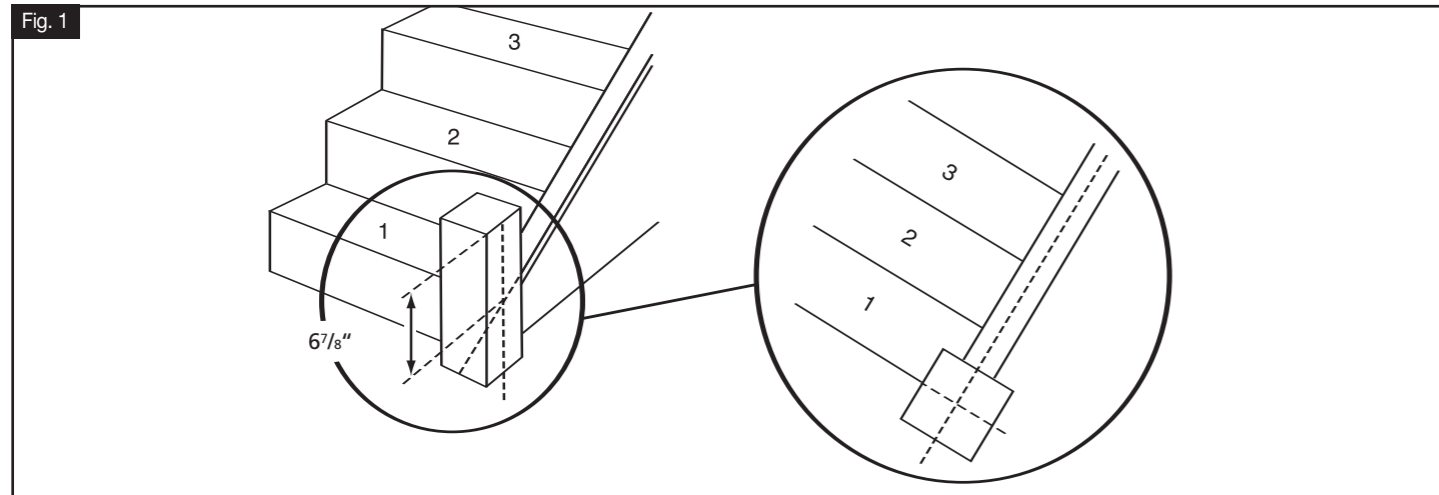



staircase configurations

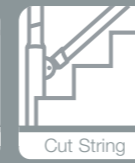

The string is the side of the staircase on which the balustrade is assembled. A cut string has the upper edge cut away to the shape of each individual step, so that the profile can be seen from the side. A closed string has the face housed to accommodate the steps, so that their profile cannot be seen. For full fitting instructions for both closed and cut string, please see the installation instruction leaflet packed with the newel base connector FMMNC.

Straight with straight step

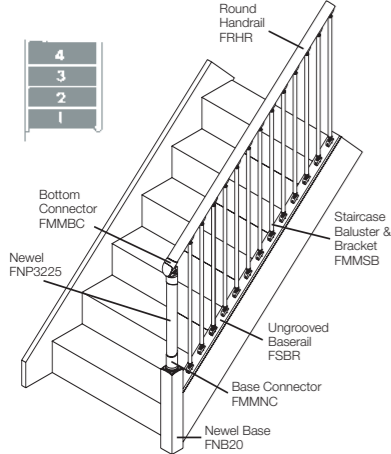

Straight with bullnose step

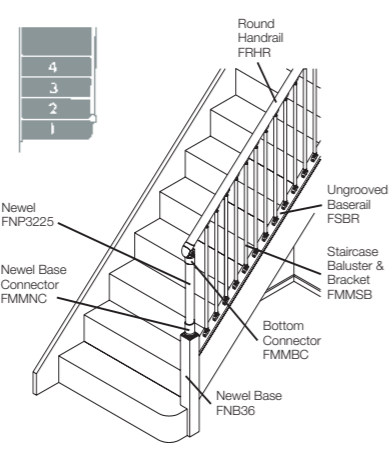

Dogleg with bullnose step

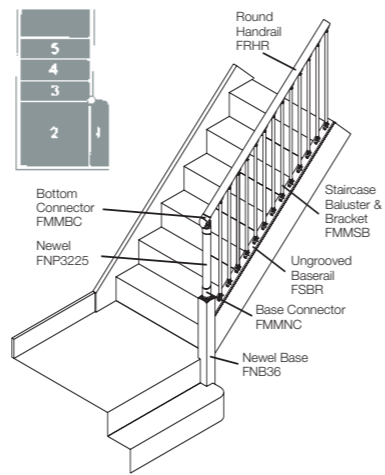

Top landing with 180° turn

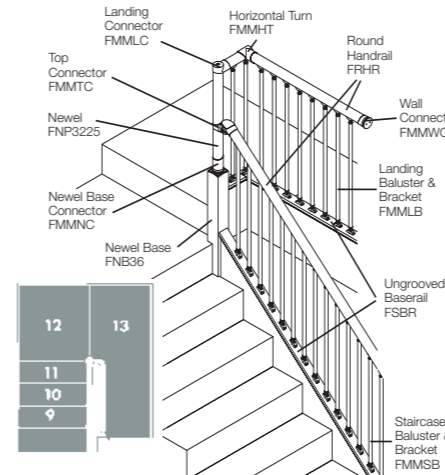

Top landing with 180° turn

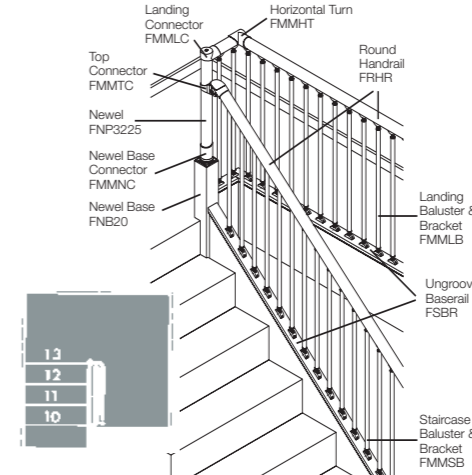

Winders

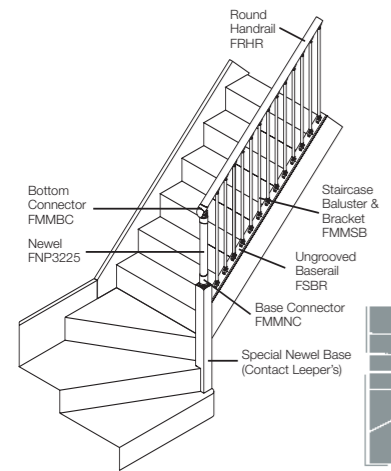

Dogleg with double bullnose and pulpit end

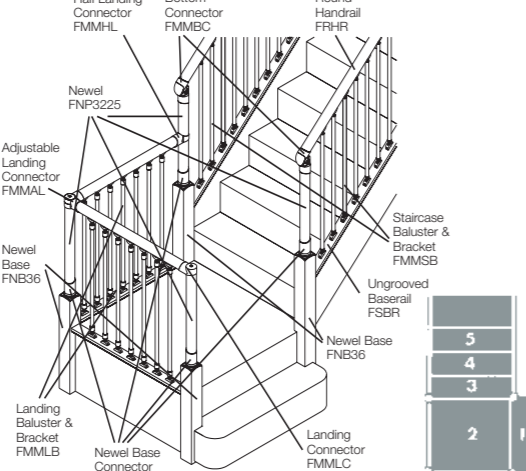

Quarter turn with landing

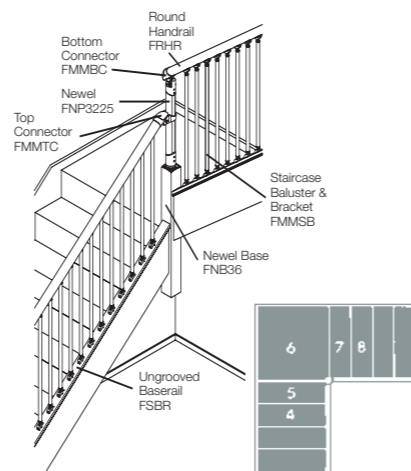

Top landing, 180° turn with winders

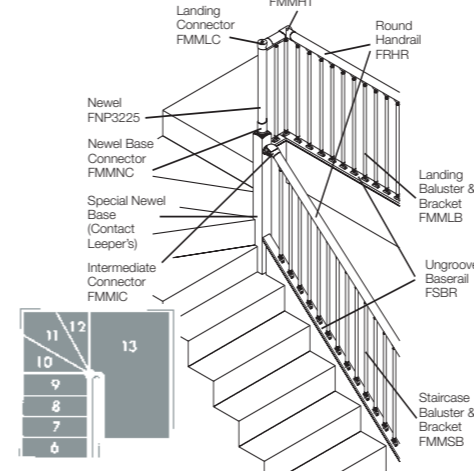

Continuous rail over newel

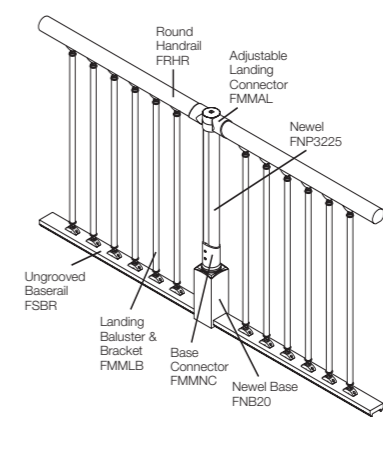

Quarter turn with 3 winders

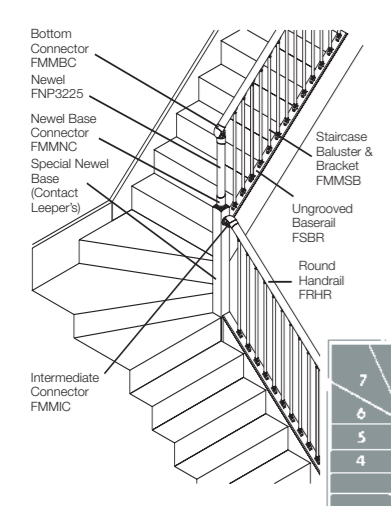

Half turn with extended landing

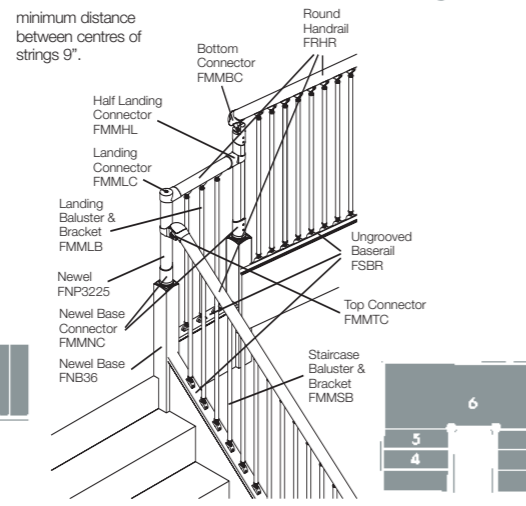

Top landing with 90° turn

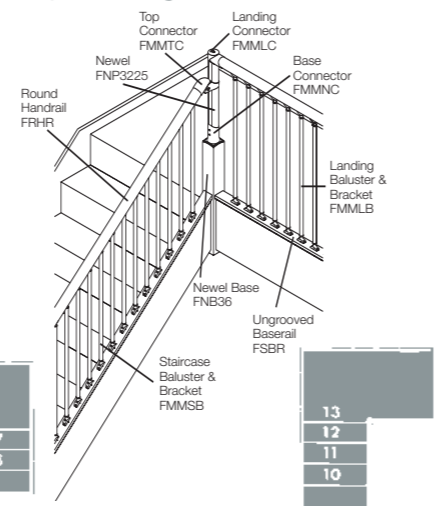

90° turn with straight rail (with newels)

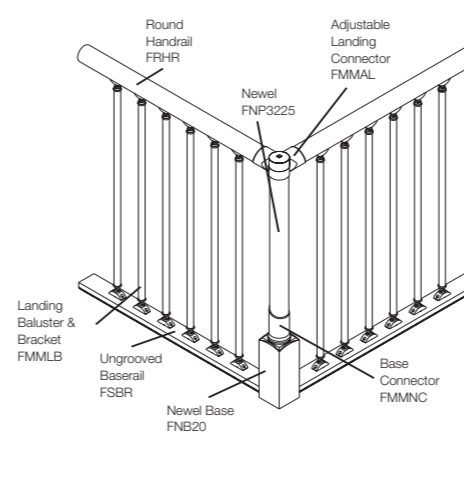

Landing or horizontal balustrading only

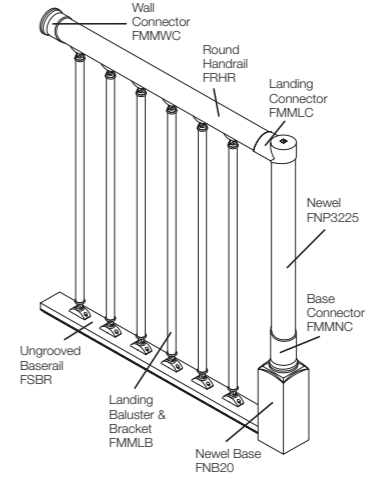

Staircase configurations with cut string option

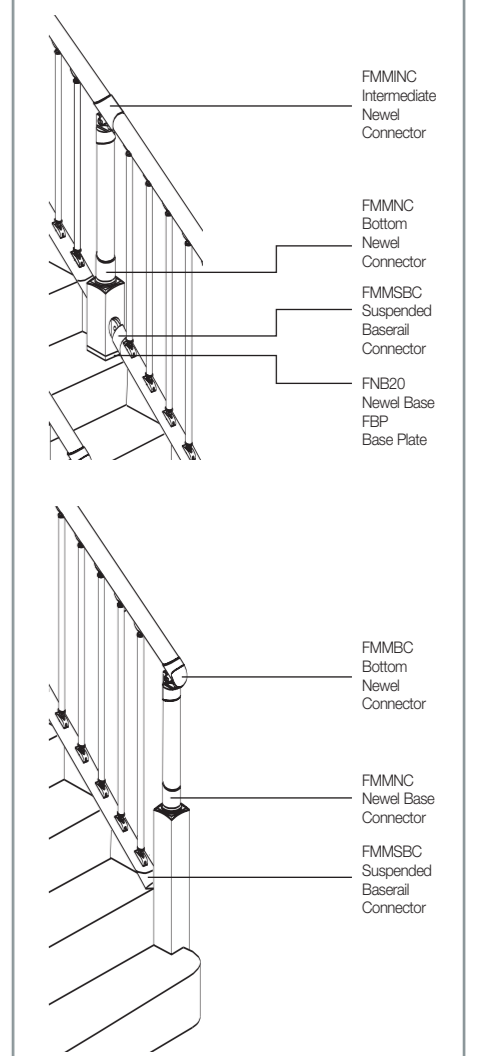

All of the closed string configurations can also be achieved on a cut string (as highlighted above). Installation instructions for both cut and closed string staircases are available with every newel base connector (FMMNC).

components list

Connectors and Balusters are available in these finishes...



Chrome Plated



Brushed Nickel



On-Line Planning Service

Plan your own Fusion™ staircase by accessing the 'On-Line Planning Service' via our website www.stairplannerusa.com (look out for this symbol).

Connectors



Newel Base Connector Connects the newel base to a newel post.
Chrome: FMMNCCR
Brushed Nickel: FMMNCBR



Bottom Connector Connects bottom post to the staircase handrail.
Chrome: FMMBCCR
Brushed Nickel: FMMBCBR



Top Connector Connects the staircase handrail to the top post.
Chrome: FMMTCCR
Brushed Nickel: FMMTCBR



Intermediate Connector Connects a handrail to a mid post where the staircase turns mid flight.
Chrome: FMMNICCR
Brushed Nickel: FMMICBR



End Cap Covers the top of the newel post.
Chrome: FMMECCR
Brushed Nickel: FMMNECBR



Wall Connector Connects the landing handrail to the wall.
Chrome: FMMWCCR
Brushed Nickel: FMMWCBR

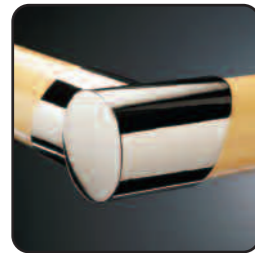

Horizontal Right Turn Connector Enables landing handrail to make a right turn.
Chrome: FMMHTRCR
Brushed Nickel: FMMHTRBR



Horizontal Left Turn Connector Enables landing handrail to make a left turn.
Chrome: FMMHTLCR
Brushed Nickel: FMMHTLBR



Staircase Baluster
Baluster length (without brackets) 720mm.
Chrome: FMMSBCR
Brushed Nickel: FMMSBBR

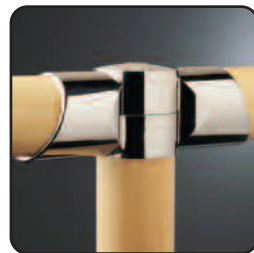

Adjustable Landing Connector Connects handrails to a post on a longer landing.
Chrome: FMMALCR
Brushed Nickel: FMMALBR



Half Landing Connector For use between two half landing newels.
Chrome: FMMHLCR
Brushed Nickel: FMMHLBR



Landing Connector Connects the landing handrail to the top post.
Chrome: FMMLCCR
Brushed Nickel: FMMLCBR

Balusters



Landing Baluster
Baluster length (without brackets) 850mm.
Chrome: FMMLBCR
Brushed Nickel: FMMLBBR

Timber Options

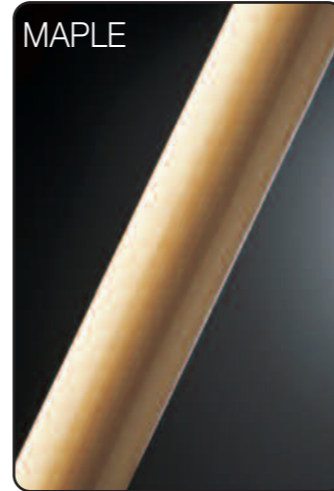

MAPLE



OAK

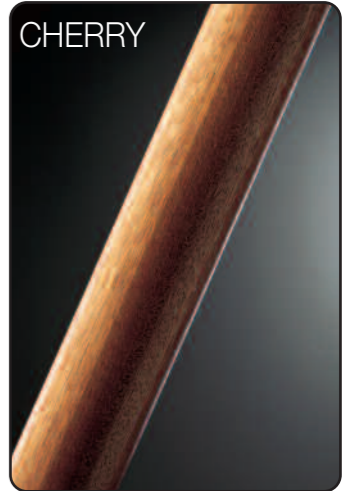

CHERRY

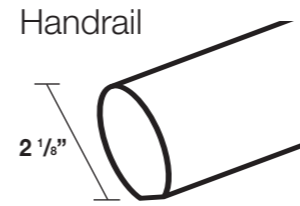

Handrail

2 1/8"

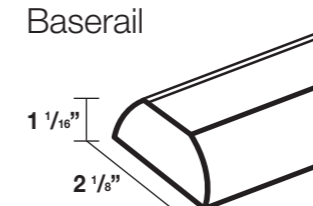

Baserail

1 1/16"
2 1/8"

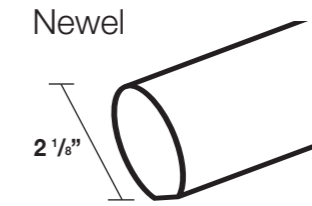

Newel

2 1/8"

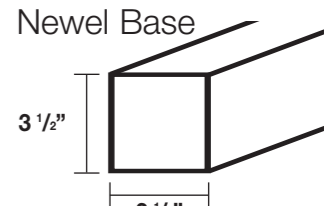

Newel Base

3 1/2"

3 1/2"

Connectors (for Cut String)



Suspended Baserail Connector Connects a suspended baserail to the newel post.
Chrome: FMMSBCCR
Brushed Nickel: FMMSBCBR



Intermediate Newel Connector Connects the handrail to an intermediate post.
Chrome: FMMINCCR
Brushed Nickel: FMMINCBR



Mid Newel Base Plate Connects a mid newel base to the stair tread.
FBP

	Oak	Maple	Cherry
Handrails	FRHR8OA FRHR12OA FRHR14OA	FRHR8MA FRHR12MA FRHR14MA	FRHR8CH FRHR12CH FRHR14CH
Baserails	FSBR8OA FSBR12OA FSBR14OA	FSBR8MA FSBR12MA FSBR14MA	FSBR8CH FSBR12CH FSBR14CH
Newel	FNP3225OA	FNP3225MA	FNP3225CH
Newel Bases	FNB20OA FNB36OA	FNB20MA FNB36MA	FNB20CH FNB36CH